

GEMCAR

Correlation between testing and simulation

Pascal GONDOT

Aérospatiale Matra CCR

GEMCAR

 AÉROSPATIALE MATRA
CENTRE COMMUN DE RECHERCHE

Overview

- Introduction
- 3D model validation in aeronautics
- 3D model validation in automotive applications
- Antenna and chamber models
- Electrical network models validation
- Hybrid methods: electrical network and 3D models
- Conclusions

Introduction

- Validation of numerical methods and models against measured results
 - academic cases to focus on specific phenomena
 - validation of specific numerical algorithm
 - validation of particular models (coupling via small apertures, coupling on wires ...)
 - real cases to show the potential applications and accuracy of modelling tools

3D model correlation

- Aeronautical applications: current injection on a structure (aircraft body)

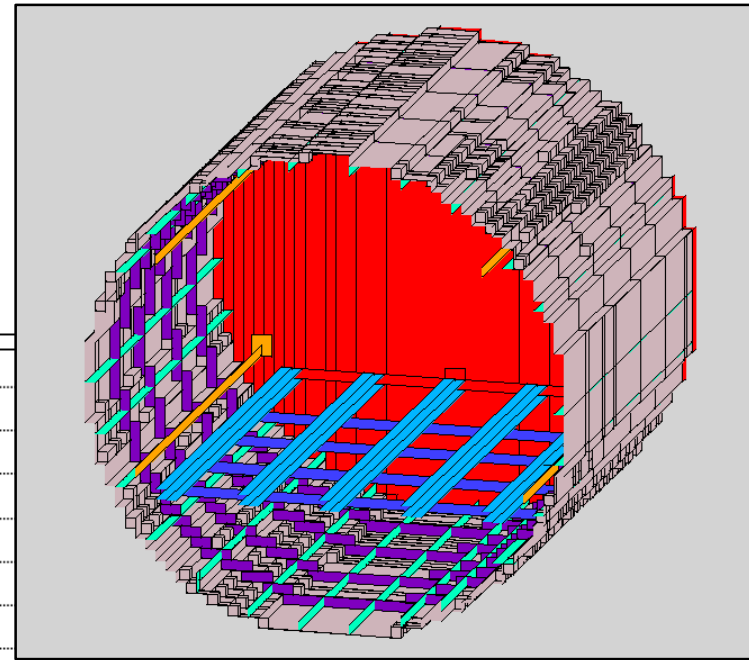
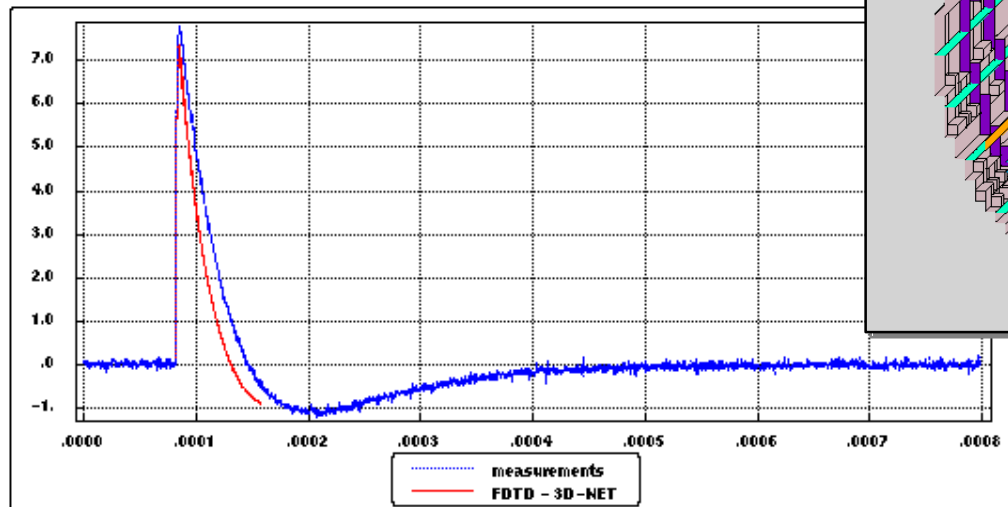

3D model correlation

- Automotive application : field coupling into a vehicle (bodyshell)

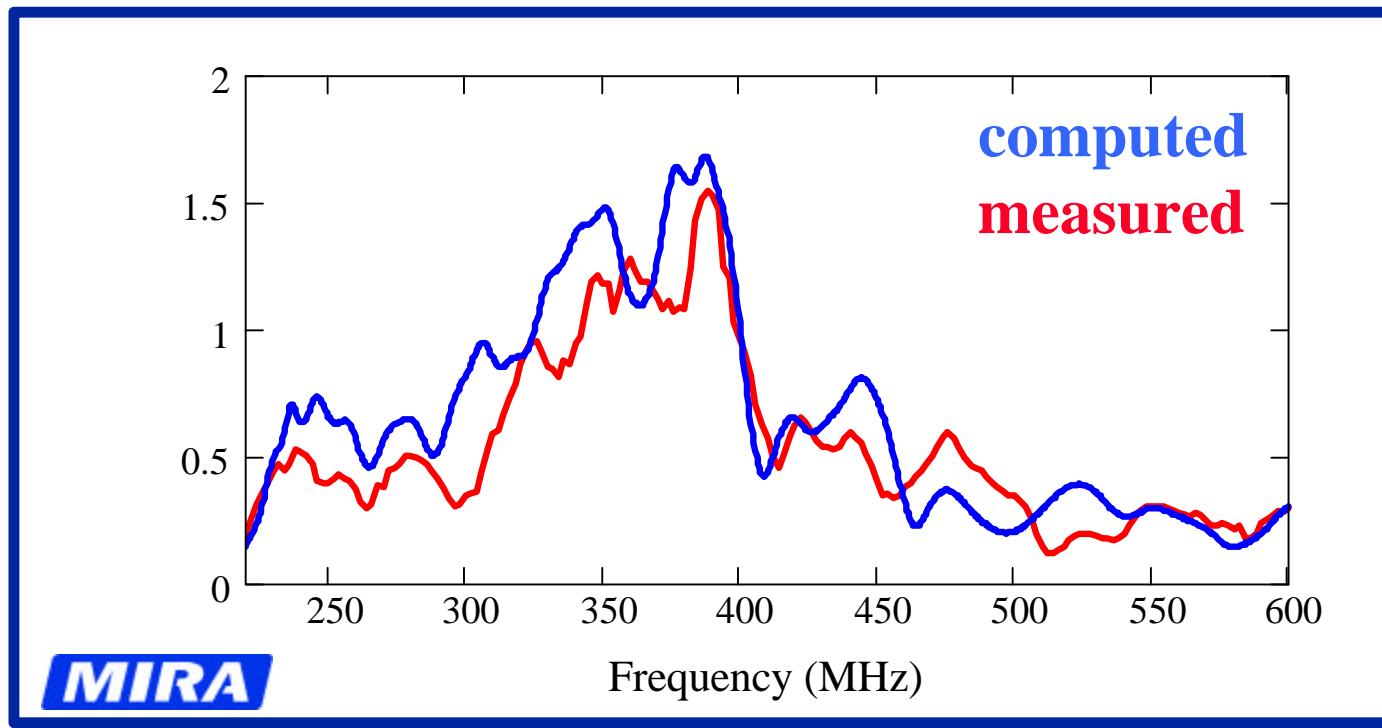

3D model correlation

- Anechoic chamber simulation: allowing the measurement environment effect to be included in models

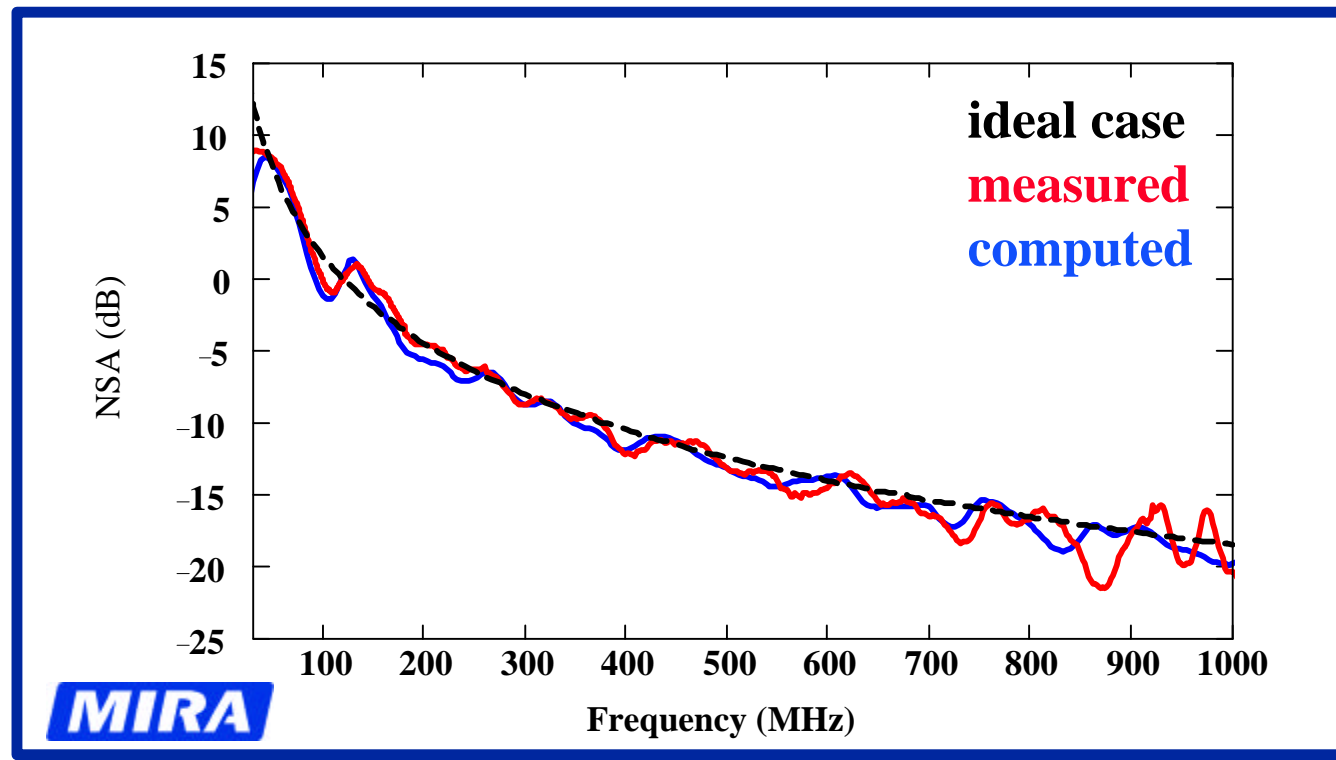

3D model correlation

- Antenna applications: VHF antenna on an aircraft - radiation pattern

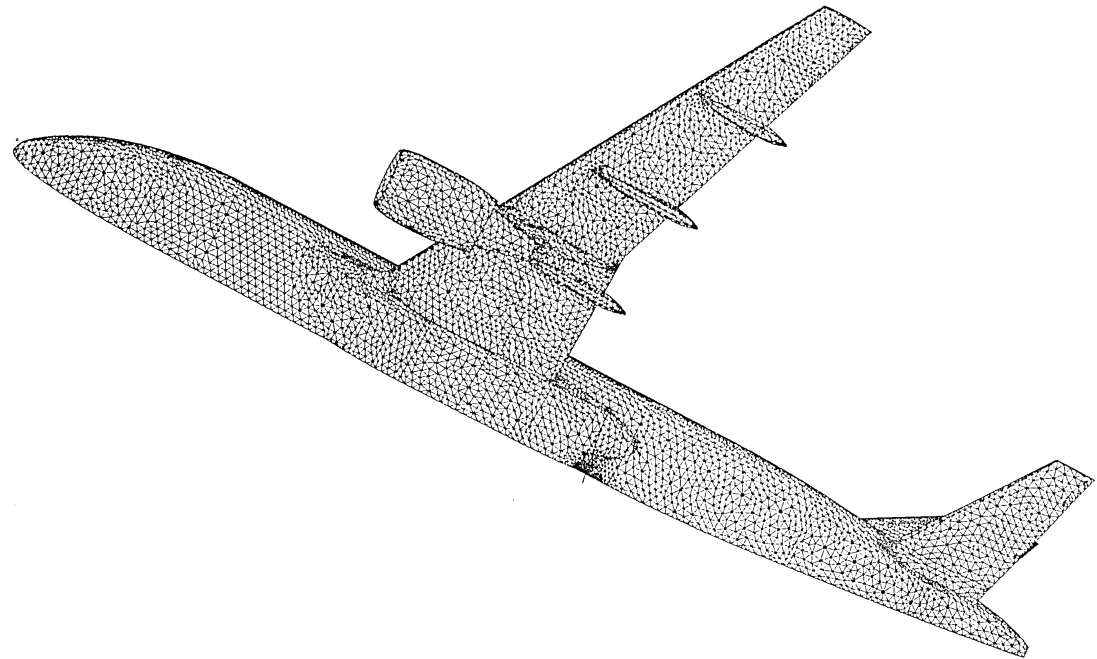
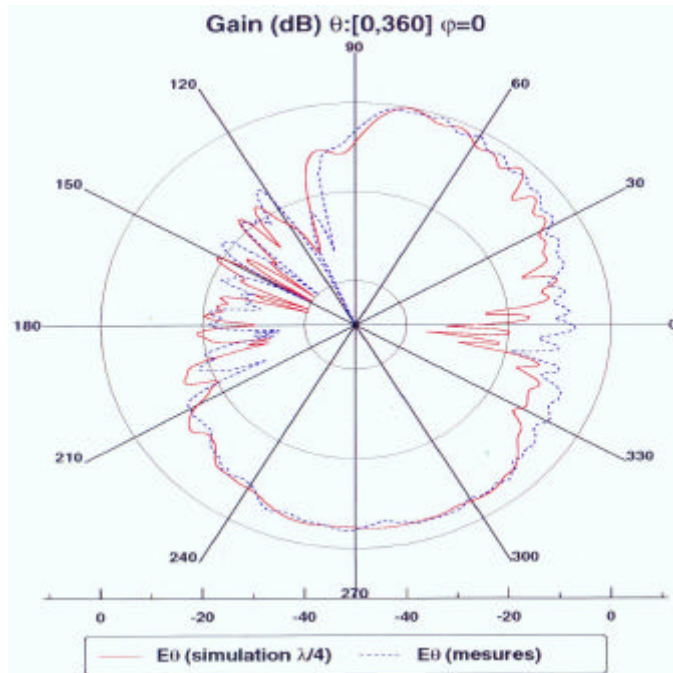

Electrical network model correlation

- Coupling on harness into a box: hybrid method - coupling between 3D and electrical network method

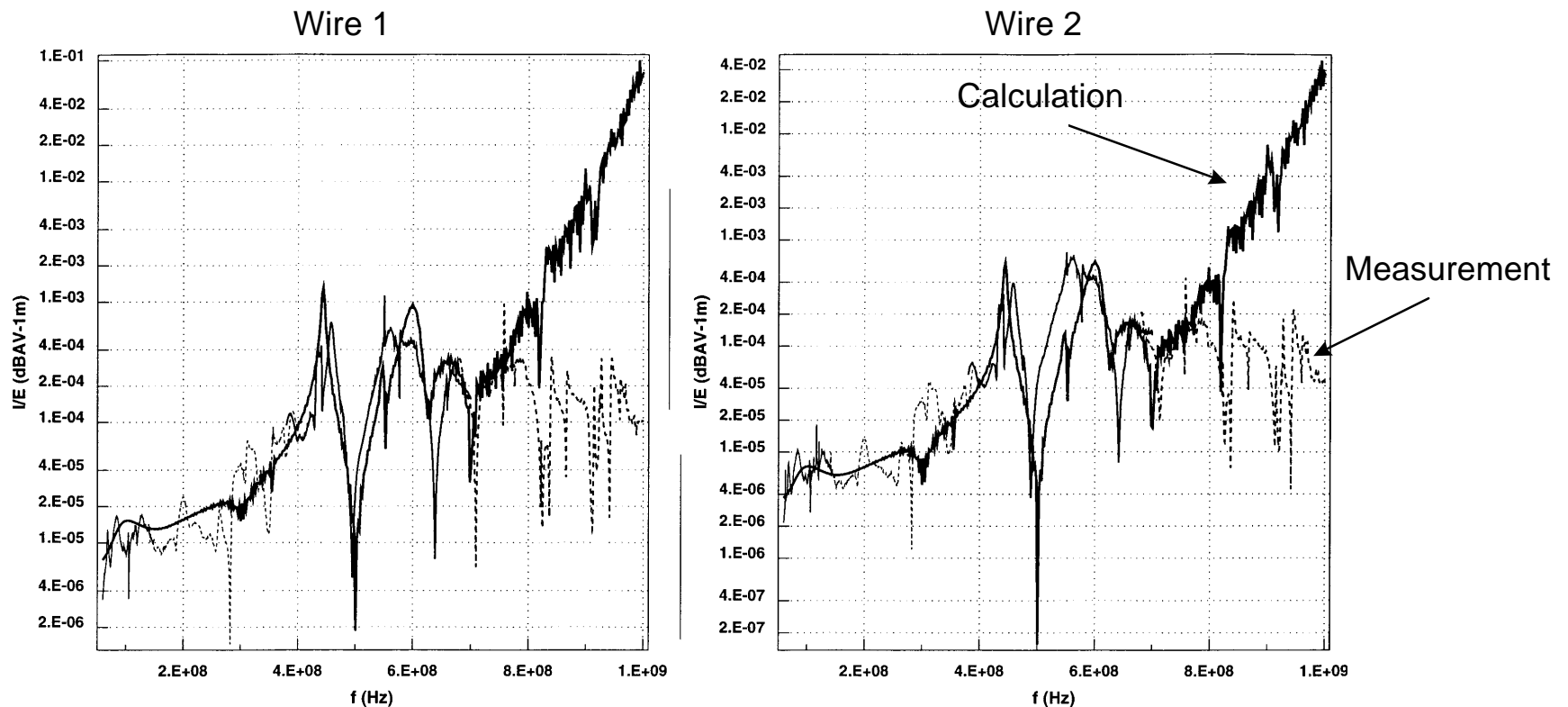

Conclusions

- Electromagnetic modelling tools are credible
 - correlation of measured and computed results is very good for simple geometry and almost as good as experimental repeatability for complex cases
- GEMCAR will complete this list of validation data and applications